

Electro-Voice

ELECTRO-VOICE, INC.
BUCHANAN, MICHIGAN

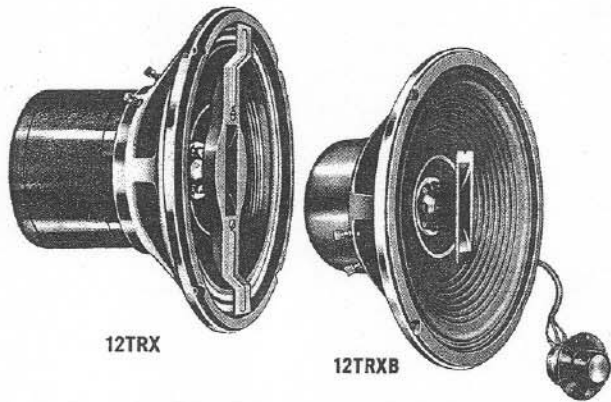

12TRX

12TRXB

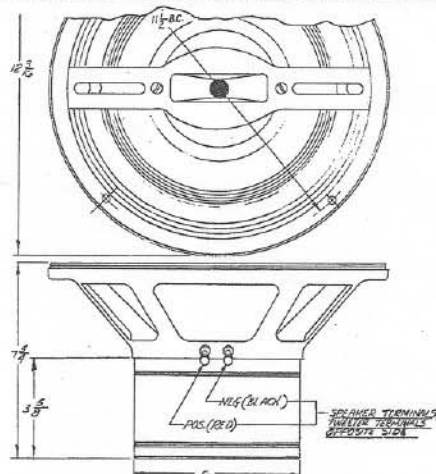

Fig. 1 — Dimensions Model 12TRX

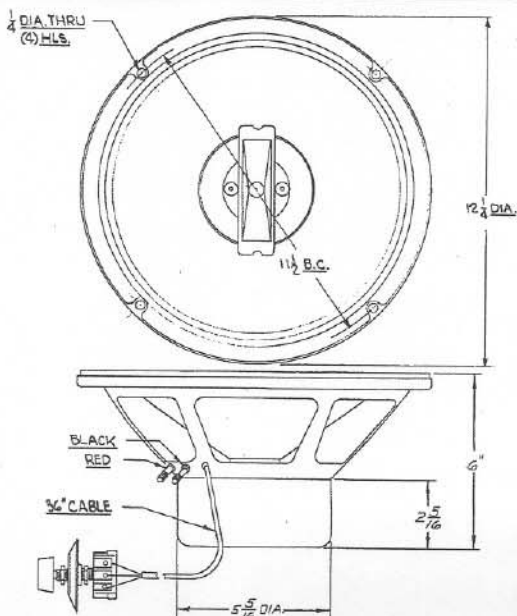

Fig. 2 — Dimensions Model 12TRXB

Specifications and Instructions

Models 12TRX and 12TRXB

Triaxial Speaker Systems

Incorporating all the design advantages of the famous E-V Radax coaxial principle, the E-V Models 12TRX and 12TRXB Triaxial Reproducers include also the latest developments in the art of reproducing the highest audible frequencies through the use of an integral Super-Sonax VHF driver. The 12TRX employs the T35 VHF driver, while the sensitivity of the 12TRXB is matched by the triaxially mounted T35B. Bass response is phenomenal, affording for the first time, pleasing musical balance without the masking effects previously experienced from extended high-frequency reproduction. Tailored to optimum listening requirements, these new developments insure even, smooth coverage of the entire listening area. This is achieved by the exclusive concentric mounting design of all reproducing elements.

FEATURES — Exclusive, E-V engineered features include true concentric mounting of all reproducing elements insuring smooth room coverage; augmented balanced bass response in conjunction with smooth extended "silky" high-frequency reproduction; carefully tailored midrange characteristic to provide realism and "presence" at usual sound levels, offsetting ear insensitivity at low volume; adjustable brilliance control to allow matching to room acoustics, compensating for high-frequency absorptive effects of rugs and draperies; crossover network with full 12 db-per-octave slope minimizes distortion; edgewise wound aluminum voice coil design affording 18% more efficiency and consequent damping of transient distortion; heavy magnet structure.

SPECIFICATIONS

	12TRXB	12TRX
Frequency Response:	35 to 15,000 cps (In recommended Aristocrat Enclosure)	30 to 15,000 cps
RETMA Sensitivity Rating:	46 db	49 db
Free-Space Cone Resonance:	40-50 cps	35-45 cps
Power Handling Capacity:		
Program Material:	20 watts	25 watts
Peaks:	40 watts	50 watts
Critical Damping Factor:		
In Aristocrat enclosure:	4	2
In an infinite baffle:	2.5	1
Impedance:	16 ohms	16 ohms
Mechanical Crossover:	2000 cps	2500 cps
Electrical Crossover:	Integral 3500 cps	Separate 3500 cps
Dispersion:	1 kc - 180°; 5 kc - 130°; 10 kc - 100°	
Magnet Weight:	1 lb 3 oz	3 1/2 lb
Size:	12 1/4 in. dia. x 6 in. deep overall	12 1/4 in. dia. x 7 3/4 in. deep overall
Mounting:	Four 3/32-in. holes equally spaced on 1 1/2-in. circle	
Baffle Opening:	10 3/4 in.	10 3/4 in.
Net Weight:	10 1/2 lb	24 lb
Shipping Weight:	14 lb	32 lb

INSTALLATION

Optimum bass response with the E-V 12TRX and 12TRXB triaxial units is obtained in the E-V Aristocrat radiator Klipsch-licensed corner horn. Where a baffle is available of the "infinite" type, such as a closet, or a wall with large volumetric capacity available behind the cone, excellent results will be obtained in the accomplishment of the bass range. The ideal volume is 14 cubic feet or more, for with this volume the low free-space resonance of the bass cone becomes the controlling factor in achieving the first octaves. This response will be flat to 35-45 cps.

Where restricted space of only 4 to 8 cubic feet is available for housing the speaker, bass response will suffer and the low range will be compressed by about 1 octave. This deficiency may be offset somewhat by reinforcing the bass through porting the enclosure. Start with an opening of about 130 square inches and gradually decrease this area until most pleasing response is obtained. More accurate design data on this form of enclosure is available from the Reproducing Components Division of Electro-Voice, and in the many articles on enclosure design now published.

Reflections on the interior cavity will cause ragged response, indicated by undue reinforcement at certain frequencies and cancellation at others, unless sound absorbent material is used on at least three of the opposing interior sides. The material may be "Kimsul" 2 inches thick or equivalent. "Kimsul" is available from any building supply house as a product of the Kimberly-Clark Manufacturing Company. Glass wool or glass block is good, but must be covered with cheese cloth to confine the fibers. Blankets, jute, and rug pads are satisfactory substitutes.

MOUNTING THE SPEAKER — Cut a circular hole 10 $\frac{3}{4}$ inches in diameter. Four $\frac{1}{4}$ -inch mounting holes are provided on the outer periphery of the speaker frame. Use four #12 x 1 $\frac{1}{2}$ -inch long wood screws, or preferably drill four $\frac{1}{4}$ -inch holes on a 1 $\frac{1}{2}$ -inch circle spaced 90 degrees apart (See Fig. 3 for hole arrangement), and employ four $\frac{3}{16}$ -inch carriage bolts 2 inches long with hex nuts and washers. Secure the speaker to the front baffle, making certain that the VHF driver horn slit has its long dimension vertical. This will insure widest dispersion of the high frequencies in the horizontal plane. Tighten the retaining screws just enough to compress the speaker gasket. Do not tighten too much or the frame may be sprung out of line. This will damage the speaker unit.

Drill a $\frac{3}{8}$ -inch hole nearby and mount the high-frequency level control. (Note: The E-V Aristocrat enclosure has a predrilled hole for accepting the Brilliance level control.) Insert the AT37 level control with the lugs toward the top. Replace the AT37 dial and affix it by tightening the lock nut with a pair of long-nosed pliers. Replace the knob on the AT37 control and note to be certain that the dot on the knob coincides with the zero on the dial at maximum clockwise rotation.

OPERATION

CONNECTIONS — No. 22 fixture wire or larger can be used to connect the 12TRX and 12TRXB triaxial reproducers to the amplifier. The 12TRX has a wiring harness, and the X36 and AT37 level controls should be connected as shown in Fig. 3. Connect the two terminals on the 12TRXB to the "16-ohm" and "Common" output terminals on your amplifier. The 16-ohm impedance of the 12TRX and 12TRXB is a standard RETMA rating. A mismatch by as much as 40% may be made without affecting the reproduction or efficiency of the unit. If only an 8-ohm tap is available on the amplifier, a loss of efficiency will be just noticeable. Connected to a 4-ohm terminal, a loss of overall efficiency will be observed.

AMPLIFIER DAMPING CONTROL SETTING — If your amplifier has a variable damping control, as do all E-V units, set this control in accordance with the value in the table of specifications.

THE BRILLIANCE CONTROL — Perfect adjustment to match the acoustic conditions in any room may be made by proper setting of the brilliance control. Rooms having large amounts of overstuffed furniture or thick rugs, will require an advanced setting of the brilliance control of about $\frac{3}{4}$ clockwise rotation. Rooms with little padded material or of small size will allow best musical balance when the control is set at about $\frac{1}{2}$ rotation. The correct position of the control for any environment will be immediately apparent, bringing the highs and lows into balance and making the sound come into "focus."

E-V "BUILDING BLOCK" METHOD

The E-V Aristocrat enclosure has precut holes and mounting facilities for future expansion of the 12TRX system through the addition of the T25A midrange driver with the 8HD horn, the X8 crossover, and the AT37 level control, if further enhancement of midrange reproduction is desired. Such an addition is not possible with the 12TRXB because of the integral arrangement of the electrical crossover network.

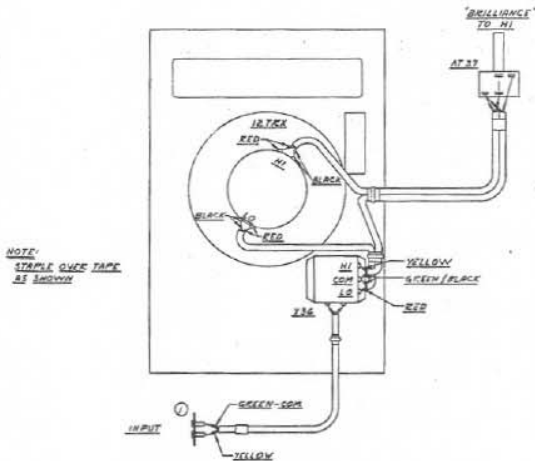

Fig. 3 — Pictorial Wiring Diagram
Model 12TRX on Aristocrat Mounting Board

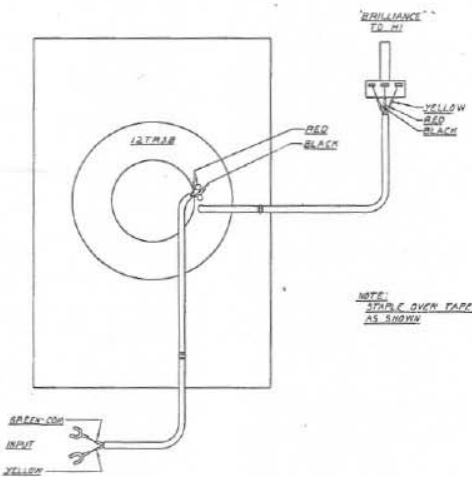
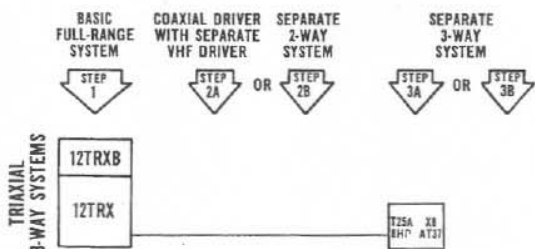
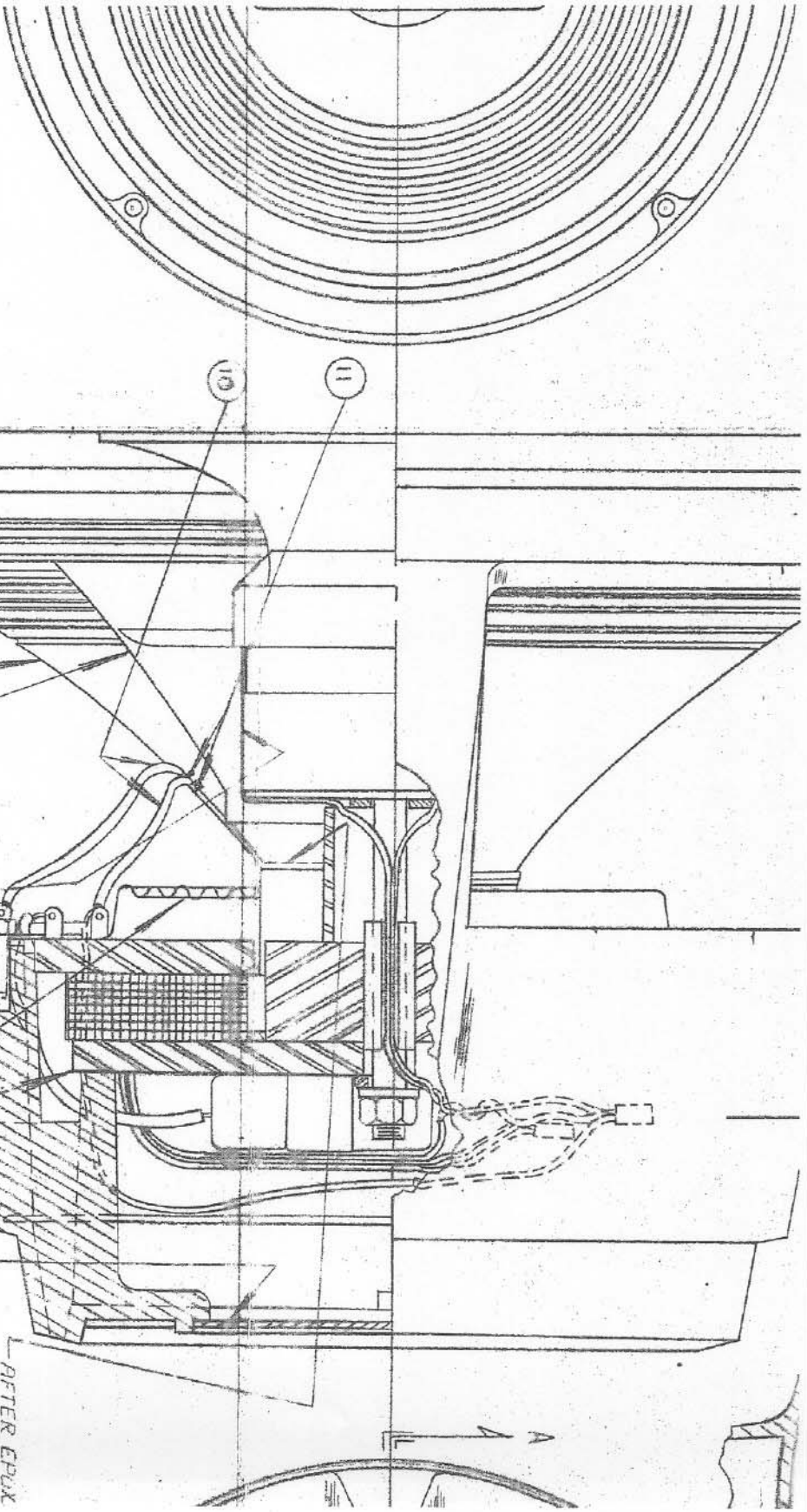

Fig. 4 — Pictorial Wiring Diagram
Model 12TRXB on Aristocrat Mounting Board



E-V "Building-Block Method" Compatibility Chart



W

ED AS SHOWN,
EM 8 TO ITEM 1
DOWN WITH
4 TO ITEM 8
TOPPIALD EVS713LA

SECTION: AA
FULL SCALE

YELLOW

AFTER EPOX
TRIM REMOVAL
FORM FROM
OF COUPE.

(24)

12
16
17
19

R

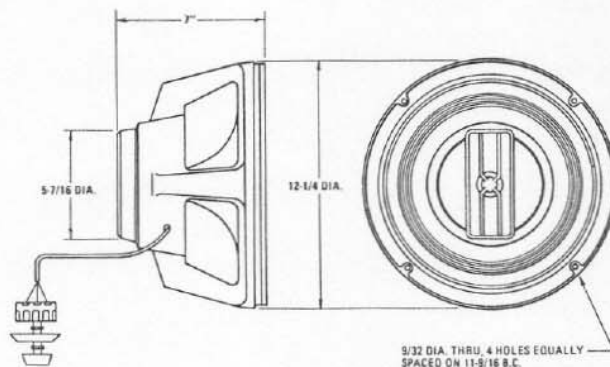
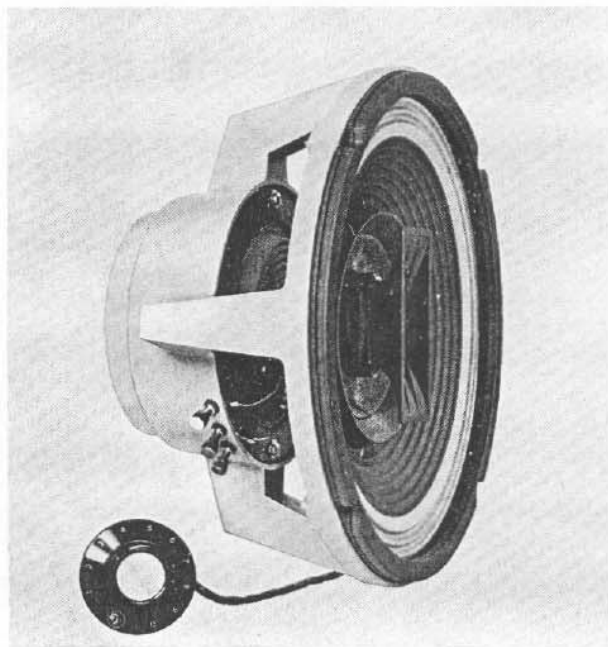

Fig. 1 - Dimensions

DESCRIPTION

Incorporating all the design advantages of the famous Electro-Voice Radax Coaxial principle, the Electro-Voice Model 12TRXB integrated 3-way loudspeaker includes, also, the latest developments in the reproduction of the highest audible frequencies through the use of an integral Super Sonax VHF driver. Bass response is excellent, affording pleasing musical balance without the masking effects previously experienced from extended high-frequency reproduction.

The 12TRXB incorporates in the high-frequency section the Sonophase throat design. Fig. No. 2 shows the cross-section of a conventional high-frequency driver. Response is flat up to 4 or 5 kHz, after which destructive interference results from inability of the diaphragm to act as a piston. Increasingly higher frequencies cause the phase of sound produced at the diaphragm periphery to shift with respect to sound produced by the diaphragm center - this being due to diaphragm deformation (See Fig. 3). In the Sonophase design, Fig. 4, sound from the central portion of the diaphragm is delayed by the longer path length, restoring proper phase relationship and level as the frequency increases. The importance of the Sonophase throat design is paramount above 12 kHz, where sound must be taken from the center of the diaphragm and the periphery simultaneously.

Further benefits are afforded in the high-frequency section of the Electro-Voice integrated 3-way speaker systems by the incorporation of exclusive Electro-Voice Diffraction Horns for maximum dispersion. In stereophonic use especially, a 3 db concentration of sound in one portion of the room is sufficient to cause an apparent displacement of the subject, with the resultant distortion of the solid or stereo effect.

An adjustable "brilliance" control is incorporated to allow matching of response to room acoustics, compensating for high-frequency absorptive effects of heavy drapery and soft furnishings.

SPECIFICATIONS

Frequency Response:	35 to 20,000 Hz
Electrical Crossover:	Integral 3500 Hz
EIA Sensitivity Rating:	52 db
Power Handling Capacity, Program Material:	30 watts
Peak:	60 watts
Nominal Impedance:	8 ohms
Voice Coil Diameter:	Woofer, 2½ in. Tweeter, 1 in.
Magnet Weight:	Woofer, 1 lb., 6 oz. Tweeter, 3.16 oz.
Flux Density:	Woofer, 10,000 G Tweeter, 10,000 G
Size:	12¼ in. dia. 7 in. deep overall
Mounting:	Four 9/32 in. holes on 11½ in. circle
Baffle Opening:	10½ in.
Net Weight:	11 lbs.
Shipping Weight:	14 lbs.

INSTALLATION

As with any quality loudspeaker, care should be taken to house the 12TRXB properly if best results are to be obtained. Excellent results may be achieved by the use of a properly designed bass reflex enclosure. Information on home construction of bass reflex enclosures is available in Technical Bulletin No. 10. Any of the bass reflex enclosures described in numerous articles may be employed, provided they are intended for a speaker of the same size and resonant frequency as the 12TRXB.

Cut a baffle opening and drill mounting holes as indicated. Use four carriage bolts, nuts and washers, or equivalent; use of woodscrews is not recommended. Secure the speaker to the baffle board just tightly enough to compress the speaker gasket. Excessive tightening is

ENGINEERING DATA 12TRXB INTEGRATED 3-WAY SPEAKER

not necessary as the compressible gasket will form an acoustical seal with nominal pressure.

Connections: No. 18 lamp cord or larger can be used to connect the 12TRXB to the amplifier output terminals. Note that the 12TRXB is equipped with three terminals, two red and one black. For normal operation, the two red terminals are connected together by a jumper wire. Amplifier connections are then made to either one of the red terminals and the black terminal. The 8 ohm impedance of the 12TRXB is a standard nominal EIA rating. A mismatch by as much as 40% may be made without affecting the reproduction of the unit. A barely noticeable loss of overall loudness will result from connection to a 4-ohm tap.

Adjustment of Level Control: Perfect musical balance to match the acoustic conditions in any room may be achieved by the proper setting of the "brilliance" control. Rooms having large amounts of overstuffed furniture or thick rugs will require an advanced setting of the brilliance control of about 3/4 clockwise rotation (3/4 fully open). Rooms with little absorptive material or of small size and having high reverberation characteristics, will give best musical balance when the control is set at about half open. In order to achieve correct setting for a particular room, rotate the control while playing a comprehensive musical passage and by careful listening, you will have no difficulty in obtaining the correct balance — the highs and lows will come into balance, placing the sound "in focus".

CAUTION NOTES

Power Handling Capacity: In program material feeding through a 40-watt amplifier, only occasional peaks actually approach a full 40 watts. The average power is much less throughout the musical range. Less than 3% of the total energy in comprehensive musical passages lies above 3500 Hz. This energy is composed of transient signals which are never sustained for long periods. Accordingly, it will be seen that the loudest passages above 3500 Hz seldom reach a total of one watt. The lowest frequency reproduction recommended for the VHF driver in the 12TRXB is 3500 Hz, and attenuation below this point should occur at the rate of at least 6 db per octave. This attenuation is afforded by the crossover network integral in the 12TRXB.

Test Precautions: A sustained tone above 3500 Hz from an oscillator such as is used for test purposes may be employed for short periods with up to 5 watts of power, but after five minutes or so, tremendous heat builds up in the sensitive driver and may damage the coil. For this reason, such tests must be of short duration. Naturally, sustained signals of this kind are never remotely approached in program material.

Precautions in Tape Machine Operation: If the speed of a tape machine is advanced beyond the normal speed, high-frequency power is quadrupled for each doubling of tape speed. On fast forward or rewind supersonic energy of great magnitude may be generated, even though the head gate is open. Always reduce volume during this process, even though the signal is inaudible. This is especially important in fast editing procedures, where the gate is frequently only partially opened so that the tape traverse can be cued audibly.

Unstable Amplifiers: Supersonic oscillation may occur in

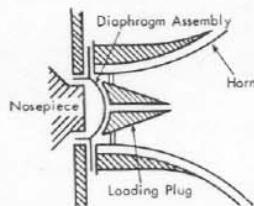

Figure 2

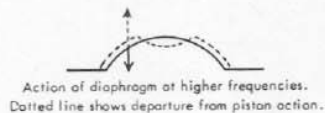

Figure 3

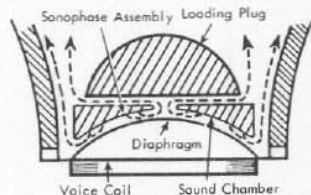

Figure 4

an amplifier whereby high-power inaudible signals may generate damaging heat in the driver units. Such oscillation may be detected with an oscilloscope, or by the presence of heat in the driver unit by feeling the pot structure of the driver. This can be corrected in some cases by using low-capacity television twin-lead between the amplifier and speaker system.

Changing Connections While Amplifier is On: Another cause of excessive power application is the changing of connections while the system is operating. The removal or plug-in of a connector may generate a tremendous surge up to the rated amplifier power. This will damage sensitive VHF driver units, treble drivers, and sometimes cone speakers. Defective switching units in the amplifier can cause a similar effect.

Feedback: Acoustic feedback may be the result of a speaker feeding back into a microphone, or it may be caused by the oscillations given off by a "microphonic" electronic component. Another common cause is the mechanical vibration from a speaker adjacent to the phono pickup or turntable. Feedback of this nature will build up at a continuously accelerating rate until some link in the reproducing chain fails, the amplifier "flat tops", or the power is reduced below the point of critical excitation. Because damage to treble and VHF units may occur, due caution should be exercised.

CUSTOMER SERVICE

The 12TRXB is packed to provide protection well in excess of shipping requirements of the Interstate Commerce Commission. If shipping damage does occur, contact the carrier or the dealer from whom the unit was purchased and request inspection and instructions.

WARRANTY

Electro-Voice high fidelity speakers, speaker systems, and accessories are guaranteed for five years from date of original purchase against malfunction due to defects in workmanship and materials. If such malfunction occurs, unit will be repaired or replaced (at our option) without charge for materials or labor if delivered prepaid to the proper Electro-Voice service facility. Unit will be returned prepaid. Warranty does not cover finish or appearance items or malfunction due to abuse or operation at other than specified conditions. Repair by other than Electro-Voice or its authorized service agencies will void this guarantee.